



VOL 08/24

August 2024

## ***PRESIDENT'S REPORT***

Presidents Report August 2024

This is my last monthly report prior to the August meeting which also includes the AGM. We are always looking to welcome members to volunteer for a committee position to manage the club's year. It would be great to see some new faces.

Unfortunately, I missed the July Meeting, but from all accounts the session run by Alan Thompson was very informative and great value to everyone. Holding your work correctly in the lathe not only is an important safety factor but also enables you to get the result you are after. Well done, Alan.

A new Presidents Challenge is coming soon. Details in the TT and at the meeting

The AGM will be run first followed by our normal meeting including Show and Tell.

We will have a sales table, a BBQ, and some top making. So, come along. Join the Committee, have a snag, make some tops, buy some more equipment, but above all have some fun and lots of chit chat.

In September we will have Cliff Walshe demonstrating Segmented Turning.

Also, we have the Schwerkolt Cottage Demo on 15<sup>th</sup> September. We need tops and help on the day. (see TT)

Remember it's Fun To Turn

Gary Jenvy



# NOTICES

## Next Saturday's Meeting

Our next meeting Saturday 24th August

### ANNUAL GENERAL MEETING

# LET'S HAVE A TOP DAY



**A**s part of the AGM we are having a silent auction of equipment and other items so bring along your unwanted or excess equipment for the table. For our new members this is a chance to purchase items for your work shop. Items in the silent auction can have a reserve price at the sellers discretion, the guild will take a 20% commission on the sale.

We are also holding a sausage sizzle barbecue for morning tea.

The cost is as follows	Sausage	3 Spinning tops
	Bread	1 Spinning top
	Sauce and/or onion	1 Spinning top



IF YOU DON'T HAVE SPINNING TOPS, DON'T WORRY, A SAUSAGE IN BREAD WITH SAUCE AND/OR ONION IS **FREE** ALONG WITH THE TEA AND COFFEE

THE LATHES WILL BE AVAILABLE TO TURNERS WHO WISH TO MAKE SOME TOPS ON THE DAY.

WE ARE WANTING SPINNING TOPS FOR OUR UP COMING DEMONSTRATION DAYS AT SCHWERKOLT COTTAGE AND THE NUNAWADING SPRING FESTIVAL

## Show and Tell

Come to the meetings and bring along some items for Show and Tell.

If you haven't got a new item you have been working on, bring an older item.

It would be good to see these also.

Even items that haven't quite worked out, members are happy to offer advice and help out.

## ACCESS TO THE WEB SITE

Could you all please note that for access to our website you just need the password and no longer need to create a user ID.



### Monday Night Discussion Group

Monday night discussion group attendance has slowed over last few weeks, probably due to the colder weather and the shorter days.

Monday night discussion group is aimed at helping new and experienced turners solve problems, improve techniques and finishing objects to obtain very high level of finish.

### Wednesday Group

The Wednesday group is a group of more experienced turners who work independently but often share tips and advice. If you feel confident there are still some vacant lathes every week. John Dunn has recently moved from Thursday into the Wednesday Group

### Thursday Group

If you know of anyone interested in learning wood turning please encourage them to come to our Thursday session of some expert tuition.

We had 4 new members commence recently

All is going well, new "WhatsApp" group is working

successfully, and the mentors can turn up knowing they have a group to assist.

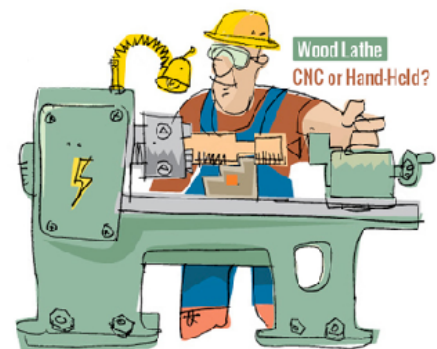

## Free CAD Software

David Tonkin has kindly provided details of some free CAD software available through Autodesk, and also an article on how to best use the software to produce a 3D image of your design.

This article is reproduced with the kind permission of the American Association of Woodturners, refer to [woodturner.org](http://woodturner.org) for further information about AAW

I will forward his email separately for ease of accessing the links

## UPCOMING EVENTS 2024



### Standing invitation

Members of CWC clubs have a standing invitation from Mike Davies to watch Record Power's free live international woodturning demonstrations. Further information from <https://recordpowertv.com/>

### 2024 Events - What does your club have planned?

I'm pleased that clubs have started to organise their events now that we seem to have reached our "new" normal. Please let me know if your club is planning an event during 2024 (or beyond) - or you know of other activities that would be of interest to fellow Woodies - we're happy to include it on the listing (but please give plenty of notice). Lots of members travel and are interested to know about event that might be on when they are in that area.

- The **Cooroora Woodworkers Club** Annual Woodcraft Show is being held on **11 & 12 October 2024** at the Cooroy Memorial Hall, Maple Street, Cooroy, Qld. There will be demonstrations of carving, turning, scroll sawing, pyrography and more will be continuously held during the show as well as competition exhibits and a raffle. Available for purchase will be a variety of beautifully finished timber pieces including milled timber. For further information, email [show@cooroorawoodworkersclub.com](mailto:show@cooroorawoodworkersclub.com) or contact Donna Horn on 0409 069 904
- The **Goulburn Valley Woodworkers Annual Wood Show** will be held on **26 - 27 October 2024** at the Multipurpose Pavilion, Shepparton Showgrounds, Archer Street, Shepparton. Along with our usual demonstrations and exhibitions, this year we will also be hosting the bi-annual National Scrollsaw Network Competition and Exhibition. Further information from their website at [www.gvwoodworkers.com.au](http://www.gvwoodworkers.com.au). Enquiries to [gvwoodworkers.show@gmail.com](mailto:gvwoodworkers.show@gmail.com)

### Snippets from Australian Wood Review

Article - [Intarsia woodworking](#)

Article - [Searching for Simplicity](#)

Project - [Making a dowel hinged box](#)

Project - [A table project](#)

Video - [Puzzle Boxes](#)

Project - [Folding phone stand](#)

Timber Sale - [Melbourne Guild of Fine Woodworking Timber sale - 20 April](#)

Article - [Widening natural edged slabs](#)

## Paul Barton Demo July 2024 (at Forest Hill Wood Turners)

By Di Bermingham, Pictures by Ian Phelan

Paul Barton's Demo at Forest Hill Wood Turners was one of the best!

His seemingly casual approach taking one by surprise!

With few tools at hand and armed with CA glue, he produced a Japanese inspired lidded container with a stick as a finial.

After recess he jammed a wet log weighing many kilos between centers, (FHWT President clung on for dear life using his body as ballast until it was round), and proceeded with the help of Gaffa tape to turn a Bowl, over 250mm, 3mm thick (you could see the light shining through it) and finished with 3 carved feet using a side grinder.

Both Items were delightful. It was wood turning at its best, fun and inspiring.

Our Hosts blessed us with delightful refreshments all day, thank you Forest Hill Wood turners for your invitation .



# SHOW AND TELL

Presented by John Mc Brin



Japanese KOKESHI doll by Alan Thompson.  
Made from Pine and hand painted

Alan Thompson also brought along this  
Christmas decoration made from Camphor  
Laurel and finished with Danish Oil



3 Pieces by Graham Besley- (L) a Ginger Jar  
with lid from Cypress Pine.

(R) Vase (deep bowl) from Eucalypt

(Below) Carved rim Bowl from Meranti.

All items finished with Danish Oil



Di Bermingham altered a slimline pen into a needle threader, but before  
she could slip the new fine wire into the old cartridge she needed to  
make a tool to knock the ball out of the cartridge

(Below) A deep hollowed bowl by Roger Annells the timber is  
unknown. Finished with "Proofseal" and Danish Oil.





4 Pieces from Val Dalsanto -

(L) A Walnut bowl

(R) A Red Gum Bowl

Below - Cypress Pine Lidded Bowl with a hand painted finial, also a Blue Gum shallow bowl or platter



Graham Churchwood brought along a Red Gum Mallet.

They always look too good to be used

(R) David Pincus showed this Burl Bowl and the "Ray Smith" duck



# DEMONSTRATION

By Alan Thompson

Today Alan gave us some very useful tips and tricks for working on the lathe if you don't have propriety or purpose made pieces of equipment

## Don't have Cole Jaws

### CONVENTIONAL JAM CHUCK



You can use a conventional Jam Chuck to hold you bowl with the tail stock up to work the base of your bowl  
Remember to take light cuts and work slowly



### PINNED BLOCKS

You can also use pinned blocks. Alan used plywood to create the base and the blocks. The blocks are nailed (pinned) and screwed to the base.

Mark the diameter of you bowl on the blocks. Attach the base to the lathe and using a square scraper above centre turn off the blocks to the markings.

Work slowly and check the fit of your bowl often bring the tail stock up to work the base of your bowl



If the fit of the bowl is a tiny bit loose use a piece of paper towel in between the bowl and the blocks to give a tighter fit.



## PINNED BLOCKS WITH CLEATS



For greater security you can add 4 cleats to the base, between the Blocks.

## A RING CHUCK

Cut three rings of the diameter. 2 ring are glued together to form a solid base the third ring has a hole cut out to take the bowl. Drill 3 holes through all 3 pieces together, mark the pieces so that they go back together in exactly the same position.

Use M10 or M12 coach bolts through the top piece. This mean there is nothing protruding our into the space in which you are working.

Sandwich your piece between the rings and tighten the nuts.



## A RING CHUCK WITH SUPPORTING BLOCK

If you have a bowl or piece of work that has a live or uneven edge you can use a packing block to keep the edge away from the base



## Don't have Long Jaws

Don't panic you might be able use your Jacobs Chuck to hold your piece of work.





### MAKE A MORSE TAPER

You could also make your own morse taper. Take one of your existing metal morse tapers take 2 accurate diameter measurements along with the distance between the 2 measurements transfer this to your block of wood and turn the taper to match metal morse taper. Press the wooden taper into the drive end align using your tail stock and commence turning a finial or icicle



### MAKE A CONE FOR YOUR LIVE CENTRE

Use a block of wood 15mm to 20mm wider than your live centre turn to round. Hollow out the end to the width of your live centre. Reverse chuck the block of wood and shape the cone end. The wooden cone is useful when you need to work close to the live centre as you won't damage your tools. Also good where you need a "soft touch" on the piece you are turning`



### MAKE A MANDREL

Use a short length of threaded rod in you Jacobs chuck. Use nuts and washers on the end, combine with spacers to suit your purposes

Alan also gave a quick demonstration on how to make a tape measure.  
 Below is a copy of the plans and also some photographs of the steps

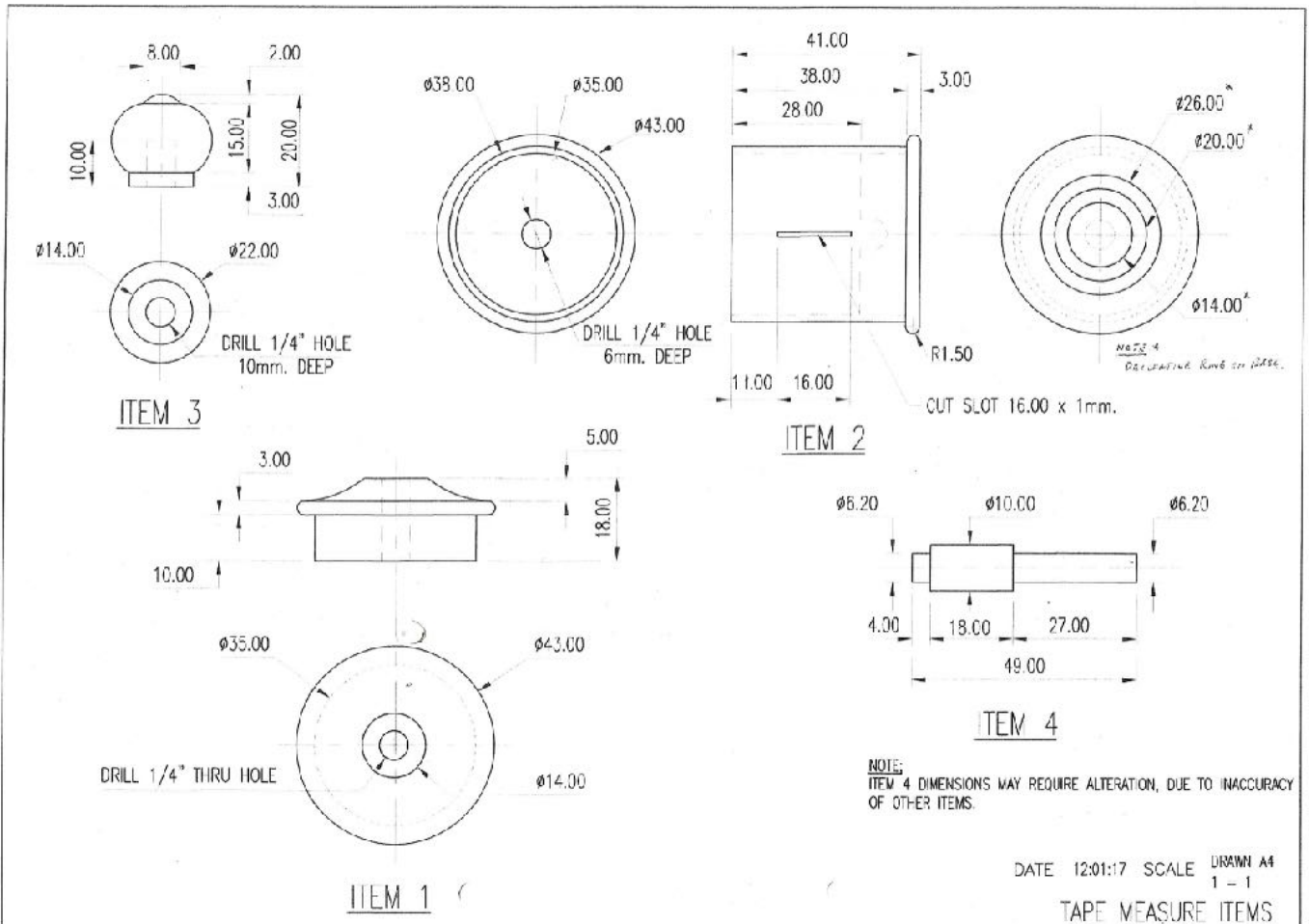

## **2023/2024 COMMITTEE**

President	Gary Jenvey		0411 593 754
Vice President	Graham Besley	14 Hunt st Nth Balwyn	0417 335 627
Secretary	Bruce Black		0402 435 759
Treasurer	Neale Rees	100 Capital Ave Glen Waverley	0403 540 574
Newsletter Editor:	Roger Annells	roger@raiddesign.com.au	0414 503 344
Committee			
Rick Hillier			0411 553 677
Ian Phelan			0413 954 071

The Koonung Woodturner's Guild meets at 9.00am  
on the fourth Saturday of each month at  
109 Koonung Road Blackburn North 3130



If unable to deliver please return to Roger Annells 8 Windsor Street Kew Vic 3101